

# VIBRAHONE™

**CB-60**



**Vibra Finish Company**

[WWW.VIBRAFINISH.COM](http://WWW.VIBRAFINISH.COM)

# CB-60 — EXPLODED VIEW DIAGRAM

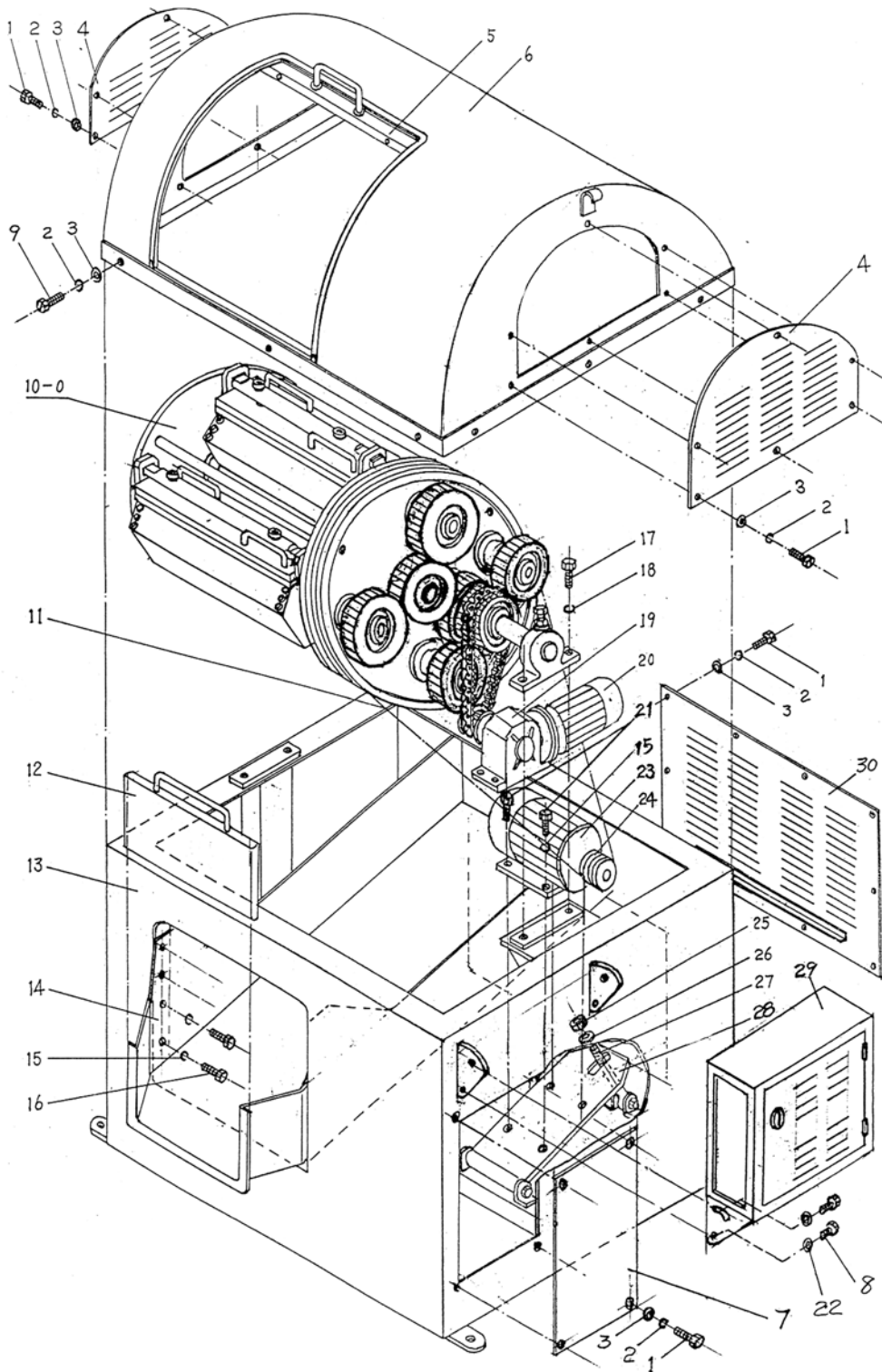

**Vibra Finish Company**

[WWW.VIBRAFINISH.COM](http://WWW.VIBRAFINISH.COM)

**CB-60 PRIMARY PARTS LISTING**  
**(refer to diagram on page 2 of 5)**



<b>ITEM</b>	<b>DESCRIPTION</b>	<b>QTY</b>
1	HEX HEAD SLOT SCREW M6X10	30
2	SPRING WASHER (∅ 6MM)	38
3	FLAT WASHER (∅ 6MM)	38
4	PROTECT PLATE IN UPPER FRAME (1.2MM)	2
5	UPPER FRAME DOOR	1
6	UPPER FRAME	1
7	SIDE PLATE IN UPPER FRAME (1.2MM)	1
8	HEX HEAD BOLTS (M 8X10)	4
9	HEX HEAD SLOT SCREW (M6X15)	4
10-0	TURRET ASSEMBLY	1
11	V BELTS "A" TYPE L=2850	3
12	UNLOAD CHUTE DOOR (3MM)	1
13	BOTTOM FRAME	1
14	UNLOAD CHUTE (3MM)	1
15	SPRING WASHER (∅ 10MM)	8
16	HEX SOCKET HEAD CAP SCREW (M10X20)	8
17	HEX SOCKET HEAD CAP SCREW (M16X40)	4
18	SPRING WASHER (∅ 16MM)	4
19	WORM GEAR SPEED REDUCER (WPDA-70A i=60)	1
20	BARREL MOTOR (Y802-6 0.55KW)	1
21	HEX HEAD BOLTS (M10X35)	4
22	FLAT WASHER (∅ 8MM)	4
23	MAIN MOTOR (YEJ112-4 3.7KW)	1
24	MOTOR PULLEY (∅ 100MM)	1
25	HEX NUT (M16)	2
26	FLAT WASHER (∅ 16MM)	2
27	MAIN MOTOR ADJUST SCREW (M16X120)	1
28	MAIN MOTOR BASE	1
29	ELECTRIC BOX	1
30	BACK PROTECT PLATE (1.2MM)	1



**Vibra Finish Company**

[WWW.VIBRAFINISH.COM](http://WWW.VIBRAFINISH.COM)

# CB-60 TURRET ASSEMBLY DRAWING 10-0

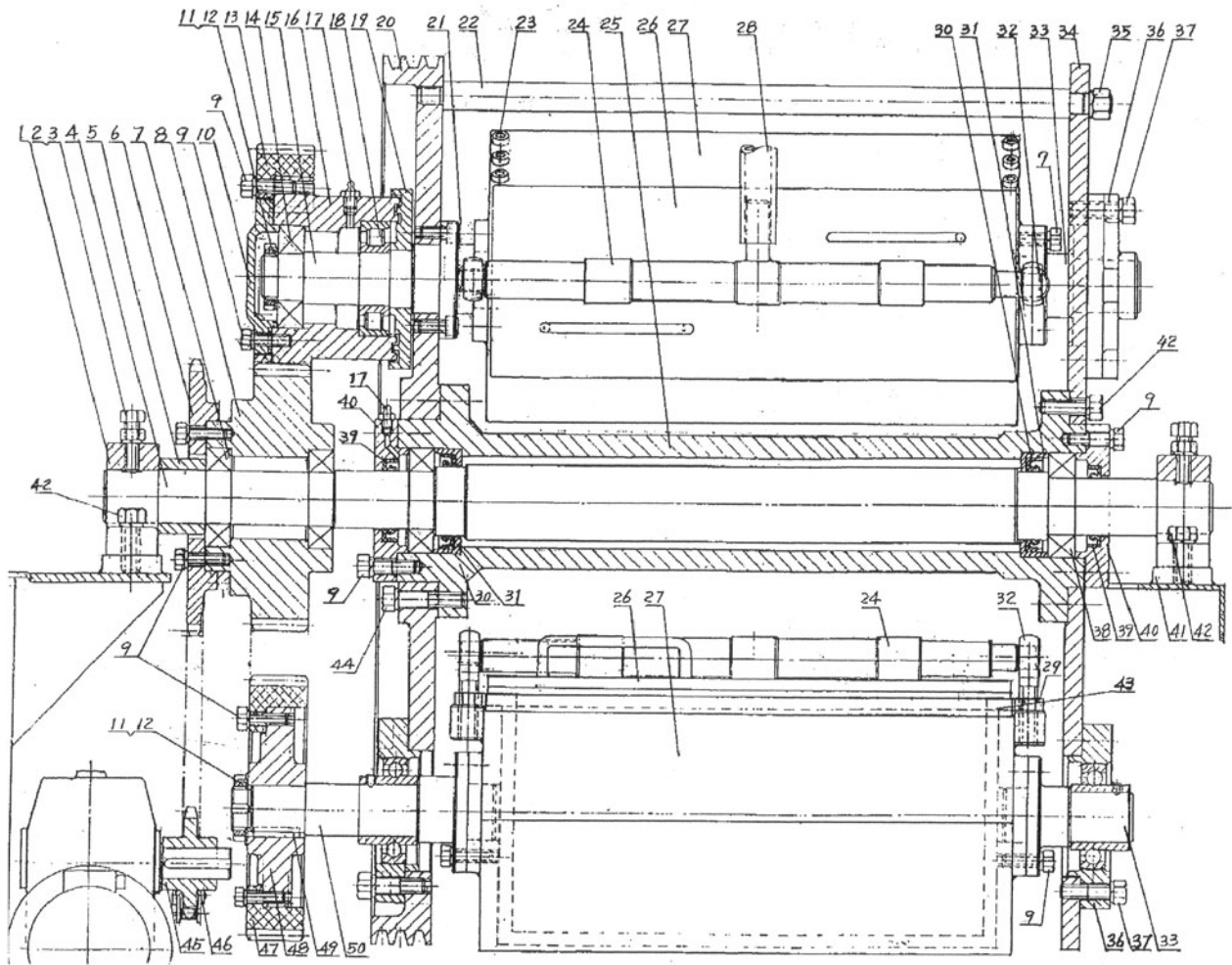

**Vibra Finish Company**

WWW.VIBRAFINISH.COM

# CB-60 TURRET ASSEMBLY — PARTS LISTING 10-0



ITEM	DESCRIPTION	QTY
10-1	SHAFT HOUSE	2
10-2	HEX HEAD BOLTS (M12X40)	6
10-3	HEX NUT (M16)	2
10-4	MAIN SHAFT	1
10-5	BLOCK SLEEVE	1
10-6	SPROCKET IN MAIN SHAFT (P=19.05 Z=38)	1
10-7	DEEP GROOVE BALL BEARING SEALED (180209)	2
10-8	GEAR IN MAIN SHAFT (M=4 Z=55)	1
10-9	HEX HEAD BOLTS (M10X35)	72
10-10	COVER FOR TRANSFER GEAR	1
10-11	ROUND NUT (M40X1.5)	6
10-12	LOCKING WASHER (ø 40MM)	6
10-13	TRANSFER GEAR (M=4 Z=39)	2
10-14	DEEP GROOVE BALL BEARING (208)	2
10-15	SHAFT OF TRANSFER GEAR	2
10-16	SLEEVE OF TRANSFER GEAR	4
10-17	OIL NOZZLE (M10X1)	4
10-18	SINGLE ROLLER BEARING (12309)	2
10-19	OIL SEAL PLATE	2
10-20	BELT ROLLER (ø 770MM)	4
10-21	HEX SOCKET HEAD CAP SCREW (M10X25)	8
10-22	HOLDING BAR (ø 25MM)	4
10-23	HEX SOCKET HEAD CAP SCREW (M8X20)	24
10-24	LOCKING BAR	4
10-25	MAIN SHAFT SLEEVE	1
10-26	BARREL COVER	4
10-27	BARREL	4
10-28	PIPE FOR LOCKING	1
10-29	NUT (M16X1.5)	8
10-30	OIL SEAL (60X80X12)	2
10-31	INSIDE BEARING COVER	2
10-32	LOCATION SCREW (M16X1.5)	8
10-33	BARREL SHAFT	4
10-34	TURRET PLATE (ø 770M)	1
10-35	NUT (M16)	4
10-36	FLANGE BEARING (FC209)	8
10-37	HEX HEAD BOLTS (M1 4X45)	32
10-38	SELF-ALIGNING ROLLER BEARING (3510)	2
10-39	OIL SEAL (50X70X12)	2
10-40	OUTSIDE BEARING COVER	2

ITEM	DESCRIPTION	QTY
10-41	SETTING PLATE FOR SHAFT HOUSE	2
10-42	HEX HEAD BOLTS (M1 6X40)	4
10-43	P/U LINING IN BARREL	4
10-44	HEX HEAD BOLTS (M1 2X60)	4
10-45	SPRKT: SPEED REDUCER (P=19.05 Z=15)	1
10-46	ROLLER CHAIN (P=19.05 L=74PITCH)	1
10-47	GEAR IN BARREL SHAFT (M=4 Z=55)	4
10-48	PLATE FOR GEAR IN BARREL SHAFT	4
10-49	FLAT KEY (A12X25)	4
10-50	GEAR SHAFT	4

### WEST

12840 Bradley Street Sylmar, California 91342  
 Tel (818) 833-0033  
 Fax (818) 833-9133  
 Toll Free 800-635-0259  
[www.vibrafinish.com](http://www.vibrafinish.com)

### EAST

8491 Seward Road Hamilton, Ohio 45011  
 Tel (513) 870-6300  
 Fax (513) 870-6311  
 Toll Free 800-253-1941  
[www.vibrafinish.com](http://www.vibrafinish.com)



**Vibra Finish Company**  
[WWW.VIBRAFINISH.COM](http://WWW.VIBRAFINISH.COM)